



CLADDING

REYNOBOND®

ALUMINIUM COMPOSITE PANELS



**REYNOBOND®**  
An Alcoa product



## INTRODUCTION

Eternit Building Materials is at the forefront of the design, development and supply of lightweight cladding solutions.

Eternit's range is now further enhanced by the introduction of Reynobond®, a versatile aluminium composite panel. As with all Eternit cladding products, Reynobond® is offered with a package of benefits to the specifier and contractor alike, from CAD facilities and system design, to on-site assistance. Each Eternit system is fully tested, proven and carries performance guarantees, with warranties also available.

Reynobond® has been extensively tested to the relevant standards and is available nationwide.

Reynobond® has been tested to BS 476: Parts 6 and 7 and in Class 0 to the Building Regulations.

## REYNOBOND®

Reynobond® provides an exceptional level of flatness together with a high corrosion resistance and has a very low coefficient of expansion. The material is easy to fabricate due to its lightness, rigidity and shock resistance properties. Reynobond® offers excellent mechanical properties and is lighter than steel and solid aluminium panels. Reynobond® weight is 3.4 times less than steel and 1.6 times less than aluminium for equal rigidity.

## CONTENTS

2	INTRODUCTION
4	APPLICATIONS
6	SYSTEM FEATURES
8	RAINSCREEN SYSTEM
9	FIXING SYSTEMS
10	COLOUR AND FINISHES
11	TECHNICAL DATA



# REYNOBOND®

## GIVES SHAPE TO YOUR ARCHITECTURAL PROJECTS

Reynobond® is suitable for interior as well as exterior architectural designs on new and refurbished buildings.

### Applications

Reynobond® can be used for the following applications:

- Ventilated facades
- Curtain walling cassette panels
- Fascias and roof edges
- Soffits
- Column covers
- Balcony cladding and infills
- Tunnel linings
- Partitioning and other interior uses

Reynobond® has the quality to behave perfectly when using large size panels where both flatness and rigidity is needed.

### Standard dimensions

Thickness: 4 mm

Dimensions: 3200 x 1000 mm, 3200 x 1250 mm, 3200 x 1500 mm

### Colourful

Reynobond® is available in a range of colours. Reynobond® can be produced to virtually any colour reference from the RAL or NCS charts subject to a minimum production quantity. Also our laboratory has the facility to match any other colours on request. (See pages 10-11 for more information on colour and finishes)

Paint topside: PVdF 70/30, or DURAGLOSS® 5000

Paint reverse side: Primer

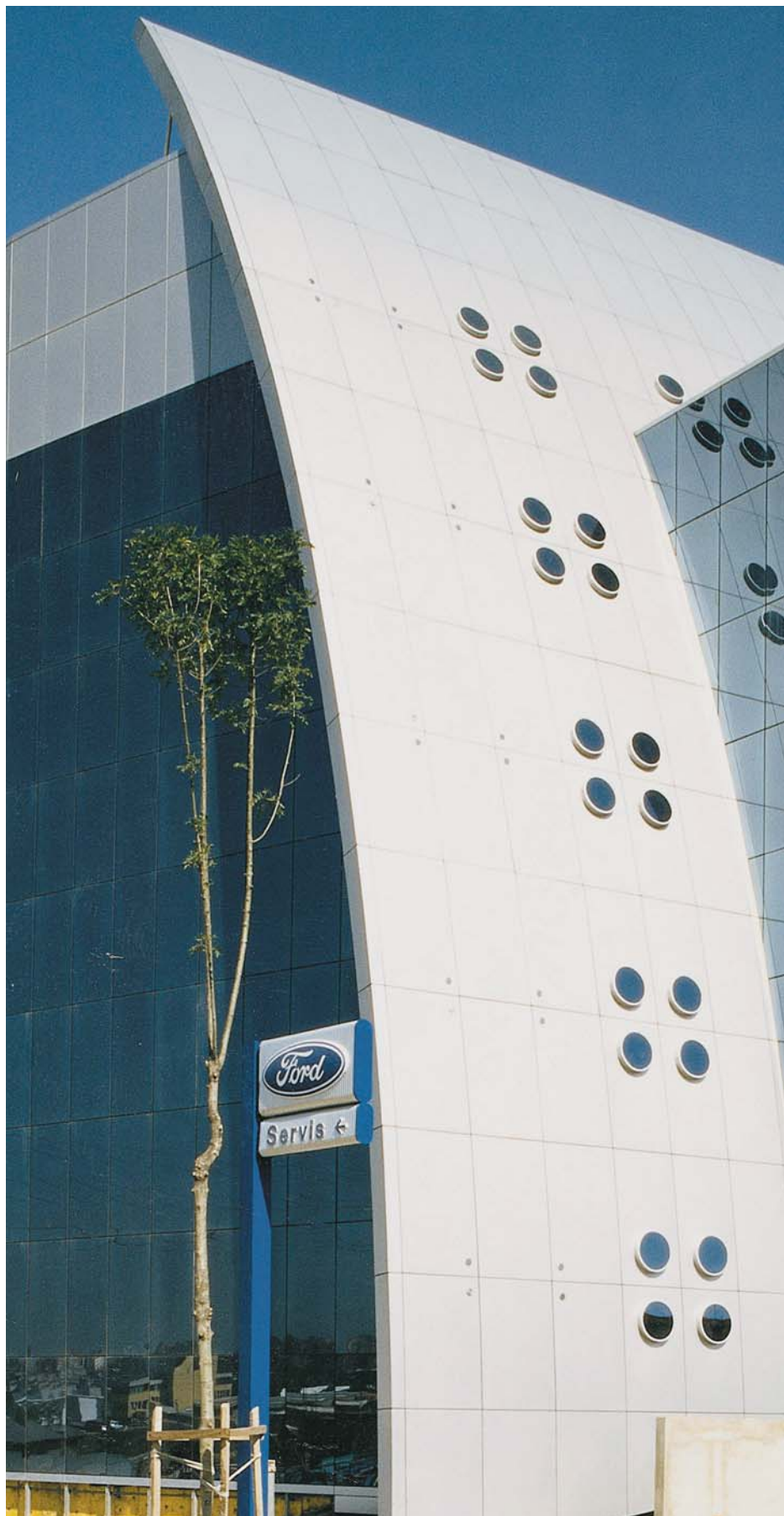

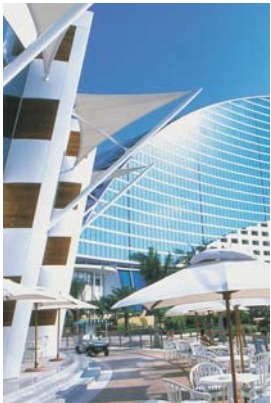
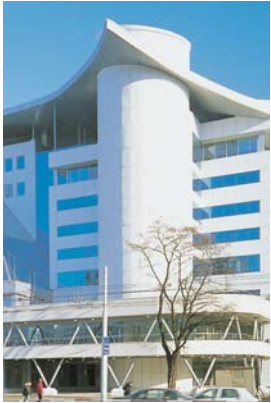

# SYSTEM FEATURES

## DESCRIPTION

Reynobond® is a composite panel consisting of a thermoplastic compound core sandwiched between two precoated aluminium sheets. Bonding of the aluminium and the core is achieved by both chemical and mechanical action, thus giving Reynobond® an extraordinary bond integrity.

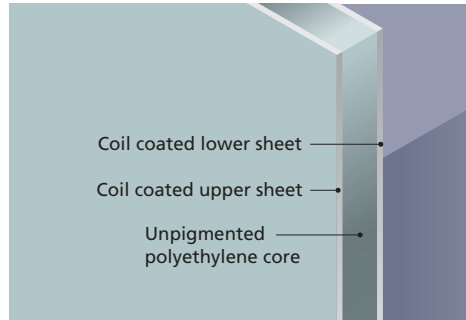

## PROPERTIES



Rigidity:  
0.240 kN m<sup>2</sup>/m  
Flexural Modulus:  
1.75cm<sup>3</sup>/m  
Reynobond®:  
4 mm -5.5 kg/m<sup>2</sup>\*  
Aluminium:  
3.3 mm -8.8 kg/m<sup>2</sup>\*  
Steel:  
2.4 mm-18.7 kg/m<sup>2</sup>\*  
\*All have equal rigidity

## LINEAR THERMAL EXPANSION

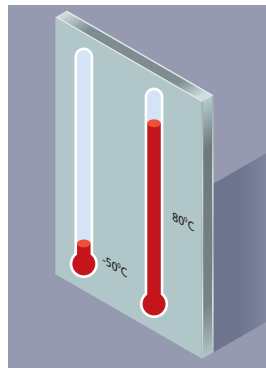

Reynobond® can be used between - 50° to + 80°C. The linear thermal expansion is of 0.024 mm/m/°C which means 1 mm/m for a thermal difference of 40°C.

## SOUND INSULATION



Thickness of panel: 4 mm  
Average airborne sound transmission loss: 26 dB

## EASY TO FABRICATE

Fabrication by way of routing, shearing, punching, drilling, bending, curving, sawing, hot-air welding or gluing and joining can be easily accomplished with rivets, screws and bolts, with standard tools and techniques. Reynobond® fabrication can be undertaken either in the workshop or on site, simplifying transport and packing.

## COATING

PVdF 70/30 and DURAGLOSS® 5000 coil coat the aluminium sheets used for the Reynobond® panels. These paint finishes are known for their outstanding resistance to strong solar radiation (UV rays) and weather conditions. (See also pages 10 and 11)

## QUALITY CONTROL AND FOLLOW-UP

Coating and laminating are controlled by a battery of ECCA and ASTM tests applied to every batch. This data is meticulously filed and provides perfect traceability for our customers



# DESIGN DETAILING

## RAINSCREEN CLADDING

With the energy saving measures required today, rear ventilated cladding systems are gaining an ever-increasing economic importance for old and new buildings.

A special characteristic of the rear ventilated cladding system is its guaranteed performance. System effectiveness is maintained even when unfavourable internal or external atmospheric conditions are experienced, e.g. in the textile industry, swimming pools, breweries etc. No other wall construction is currently able to fulfil the growing requirements for heat, dampness, noise and fire protection.

Ventilation openings should be provided at the base and top of the cladding area, together with any interruptions, windows, ring beams etc. These openings should be protected by mesh or purpose made closures to prevent entry by birds, vermin or insects. Inlet and outlet gaps should be provided according to the following minima.

Up to five storeys: 10 mm continuous

Five to fifteen storeys: 15 mm continuous

Above fifteen storeys: 20 mm continuous

A clear minimum cavity of 30 mm should be provided continuously behind the cladding panels.

Any moisture penetrating the various joints in the main cladding screen can now be effectively removed by the provision of uninterrupted ventilation paths the full height of the cladding. (See typical vertical section).

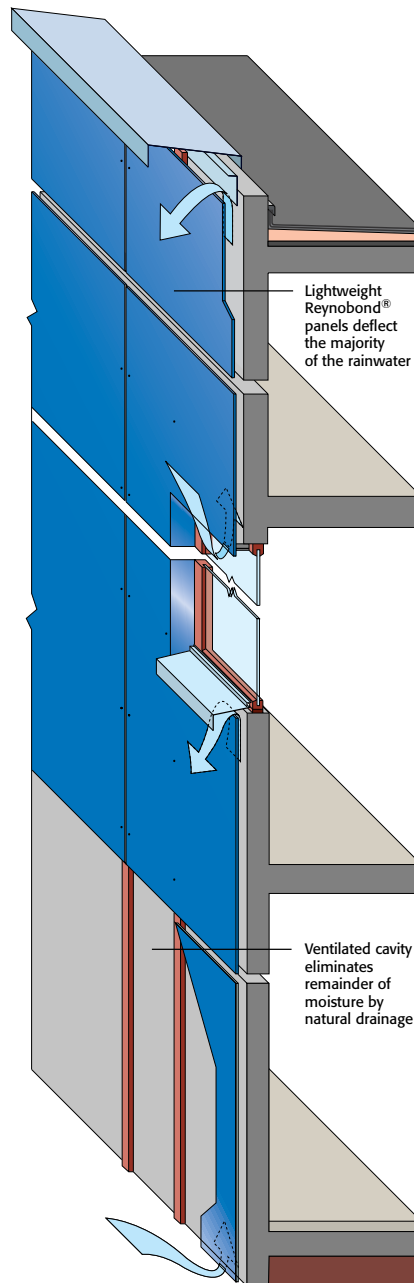

## FIXING SYSTEMS

Reynobond® was created so that comprehensive cladding processes can be carried out by using various fixing system technologies.

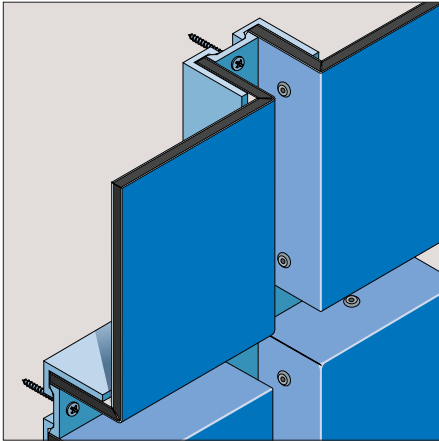

Tray system

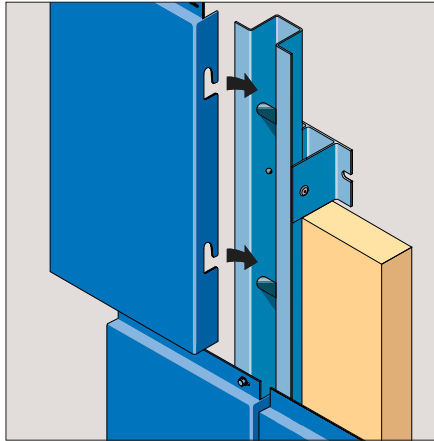

Cassette system

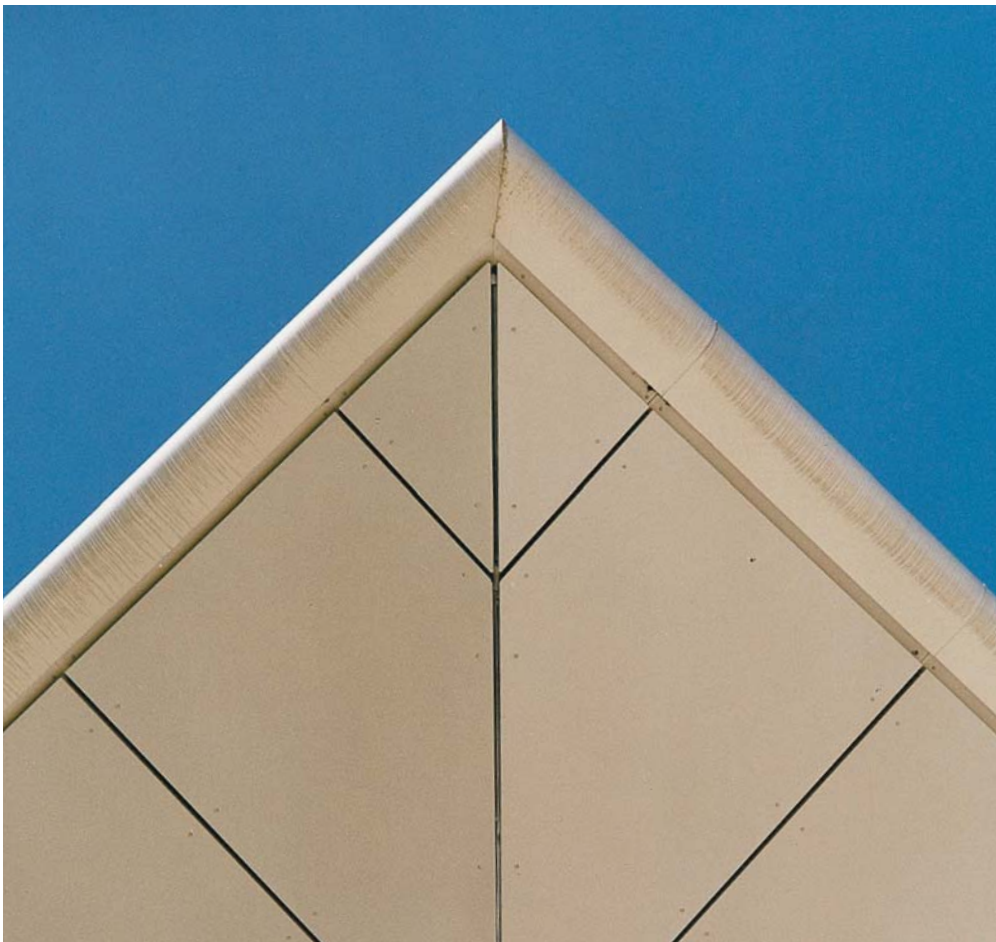

## COLOUR AND FINISHES

### ARCHITECTURAL PVDF AND DURAGLOSS® 5000 COLOUR CHART

Reynobond® composite material is available in a range of standard coil coated colours in PVDF and Duragloss® 5000 finishes. These full strength and high performance coatings have been especially selected for architectural cladding applications. The two coating systems include opaque and metallic finishes. On request, specific colours are possible providing the demand covers minimum production quantities.

#### PVDF COATING

PVDF (Polyvinylidene Fluoride) coatings contain at least 70% of KYNAR 500 resin or equivalent which are famous for their exceptional quality and durability. These coatings are obtained with a coil coating technique, and cured at high temperatures according to the procedures laid down by ECCA. It gives therefore to Reynobond® excellent surface properties and perfect formability. Specular gloss measured at 60° is about 25 to 30%. PVDF coatings are known for their outstanding resistance against various aggressive environments: colour and gloss resistance against ageing, resistance to strong solar radiation, to humidity, salt spray, pollution, and various pollutants.

#### DURAGLOSS® 5000 COATING

Duragloss® 5000 coatings are formulated with a high-tech polymer-based resin and highly durable inorganic pigments, making them suitable for a wide range of architectural and special applications. This is a 2-coat finish system consisting of a primer and top, or colour coat. Nominal film thickness is 35 microns. Duragloss® 5000 is an alternative to PVDF especially when strong metallic finishes are required.



# TECHNICAL DATA

## PVdF PROPERTIES

Coil coated aluminium Reynolux®

PVdF properties\*

Properties	Method	Coil coated aluminium Reynolux®
Coating thickness	ECCA method T1	Thickness: 24 to 30 µm
Specular gloss	ECCA method T2	Medium - Low gloss
Colour difference	ECCA method T3	Spectrocolorimeter controls with the Cielab scale
Resistance to cracking on rapid deformation	ECCA method T5	No cracking, no loss of adhesion
Adhesion after indentation	ECCA method T6	100%
Resistance to cracking on bending	ECCA method T20	Depending on the metal quality
Resistance to salt spray fog	ECCA method T8	1000 hours
Water immersion resistance	ECCA method T9	1000 hours
Acid resistance	ASTM D 1308-79	HCl at 10% solution/15 minutes/ 23°C: no attack
		H2SO4 at 20% solution/18 hours/ 23°C: no attack
Alkaline resistance	ASTM D 1308-79	NaOH at 10% solution/1 hour/23°C
		NaOH at 25% solution/1 hour/23°C: no attack
Detergent resistance	ASTM D 1308-79	72 hours immersion in a solution at 3% at 30°C Vigor: no attack
Colour fastness on natural weathering	10 years 45° South Florida	Maximum change of colour of 5 to 10 units, depending on the colour
Resistance to chalking on natural weathering	10 years 45° South Florida	Maximum 5 to 6



## DURAGLOSS® 5000 PROPERTIES

Coil coated aluminium Reynolux®

Duragloss® 5000 properties\*

Properties	Method	Coil coated aluminium Reynolux®
Coating thickness	ECCA method T1	Thickness: 35 µm
Specular gloss	ECCA method T2	35% for solid colors 25% for metallic colors
Colour difference	ECCA method T3	Spectrocolorimeter controls with the Cielab scale
Resistance to cracking on rapid deformation	ECCA method T5	No cracking, no loss of adhesion
Adhesion after indentation	ECCA method T6	100%
Resistance to cracking on bending	ECCA method T7	Depending on alloy and temper
Resistance to salt spray fog	ECCA method T8	1000 hours
Water immersion resistance	ECCA method T9	1000 hours
Abrasion resistance falling sand	ASTM D 968	>40 litres/25 µ
Acid resistance	ASTM D 1308	HCl at 10% solution/ 15 minutes/ 23°C: no effect
Detergent resistance	AAMA 620	No effect
Colour fastness on natural weathering	10 years 45° South Florida	Maximum colour change: 5 units
Resistance to chalking on natural weathering	10 years 45° South Florida	Maximum rating 8

## Technical services

Our national team of technical representatives is available to provide information, samples and design assistance and may be contacted through the office below.

## Supply

Reynobond® panels are supplied with a protective plastic film coating which should be removed after installation.

## Storage

The plastic film coating will provide short term protection, but for long term storage the panels should be stored in a building or under waterproof wrapping. Panels should be stored flat and raised off the ground.

## Handling

When handling, care should be taken not to damage the protective film or abrade the surface of the product. Once the panel has been installed the protective film should be removed as soon as possible.

## Other Eternit products

### *Other cladding products*

Agrestone reinforced glass fibre polyester panels, Lamina External high pressure laminate cladding panels Glasal NT fully compressed fibre cement, Natura, Multiclad fibre cement sheets and Weatherboard fibre cement planking.

### *Clay tiles*

Acme and Hawkins machine-made plain clay tiles, Ashdowne handcrafted plain clay tiles, Sandringham interlocking pantiles, and a range of accessories are available.

### *Profiled sheeting*

A range of profiled fibre cement roofing sheets, PVCu rainwater goods, rooflights and general purpose lining boards are available from Eternit.

## Terms and conditions

Reynobond® is a registered trademark of the Alcoa company.

The publication is based on the latest data available at the time of printing. Due to product changes, improvements and other factors, the Company reserves the right to change or withdraw information contained herein without prior notice. Engineering properties contained herein or related hereto are intended only as guidelines and for evaluation by technically skilled persons, with any use thereof to be at their independent discretion and risk. Such information is believed to be reliable, but the Company shall have no responsibility or liability for results obtained or damages resulting from such use.



### ETERNIT BUILDING MATERIALS

Meldreth, Nr Royston  
Hertfordshire SG8 5RL

tel 01763 264600  
fax 01763 262531  
www.eternit.co.uk  
email marketing@eternit.co.uk

When phoning, please quote  
reference: CLL 65